

ASL-JBH100 自動轆腳機

Automatic Bottom Hemming Machine

自動化縫製科技新世紀
New Century Of Automation Sewing Machine Technology

產品特點 | FEATURES

1 簡單的操作設定介面 User Friendly Interface



簡易操作面板，變換規格簡單快速。

Quick spec change with simple operation panel.

2 精準的自動折布結構 Precise Auto Folding



上下擺動勾布機構，輕鬆方便取放車縫布料。

Hook mechanism. Easy access to cloth.

3 模式調整 Mode Switch



車縫模式分為手動、半自動、全自動模式，變換容易。

Three sewing mode includes manual, semi-auto and auto modes.

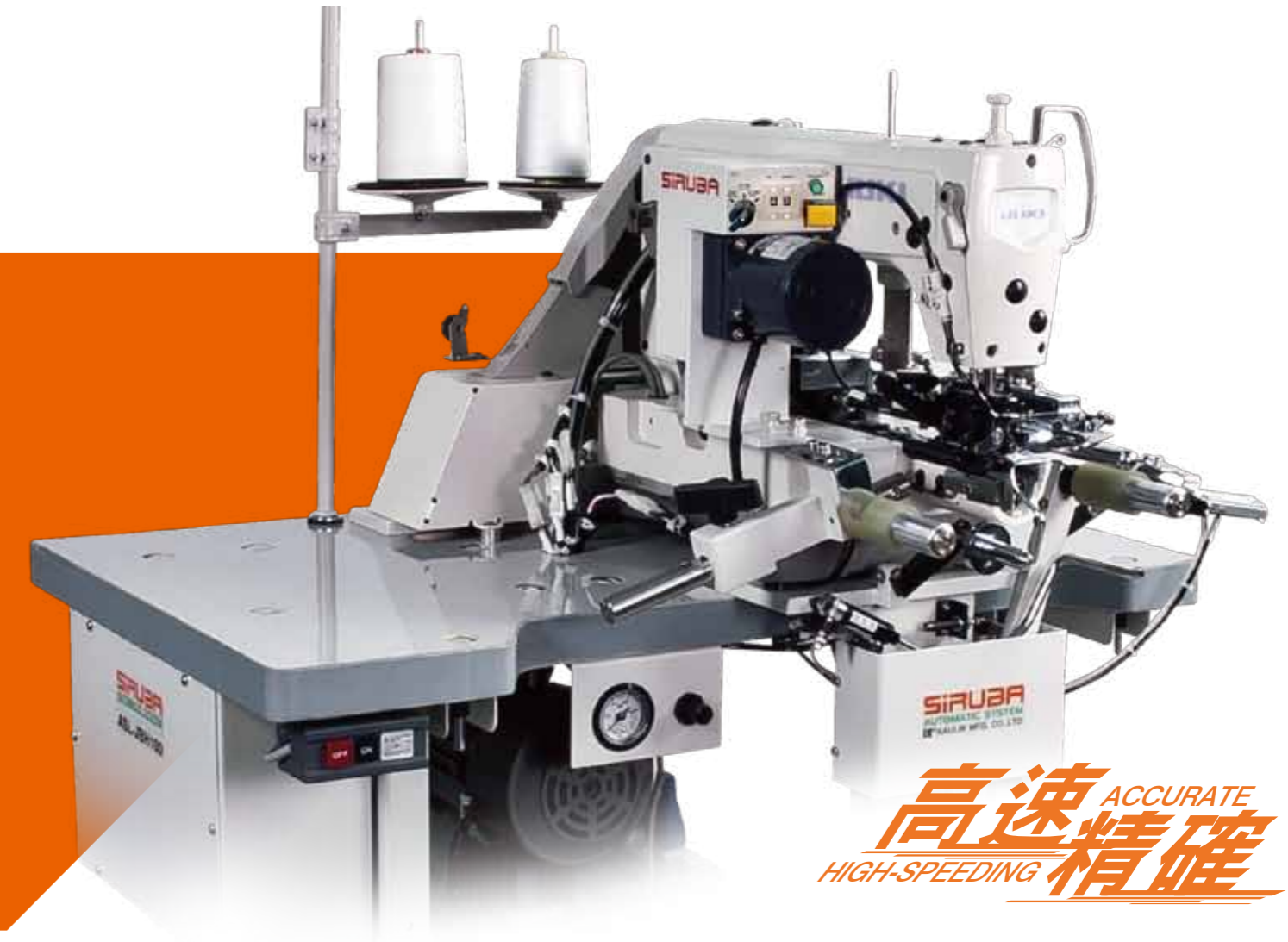

ACCURATE
高速精確
HIGH-SPEEDING

4 褲邊寬度調整變化時，可輕鬆容易的調整 Flexible And Quick Adjustment With Different Cuff Width

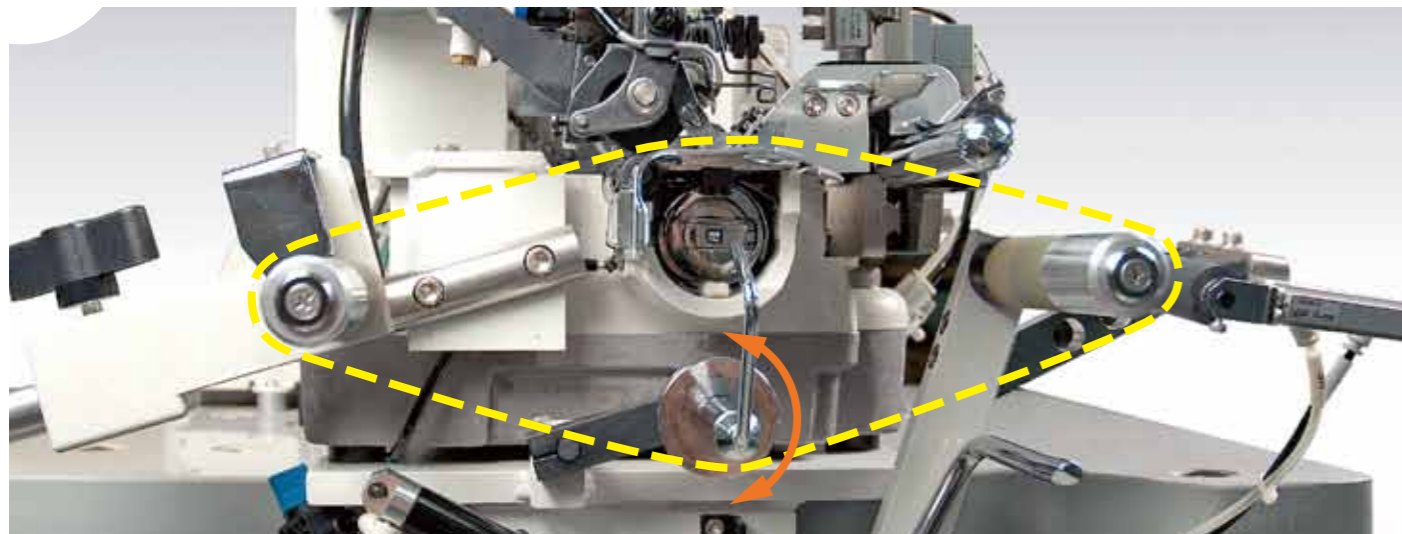

(1) 褲邊寬度 200~300mm
(1) Cuff width 200~300mm

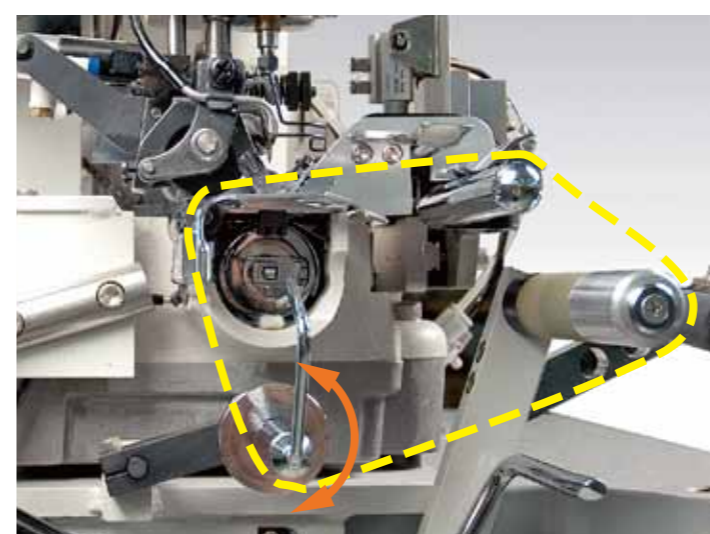

(2) 褲邊寬度 170~200mm
(2) Cuff width 170~200mm

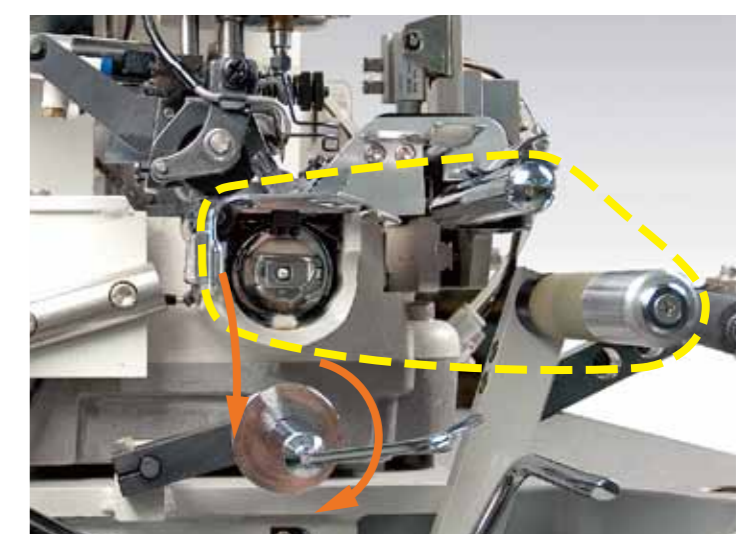

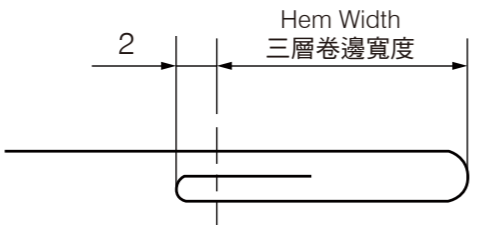

(3) 褲邊寬度 140~170mm
(3) Cuff width 140~170mm

型號 Model	ASL-JBH100
搭配縫紉機機頭 Collocation Machine Head	JUKI DLN-6390-7
車縫速度 Sewing Speed	最高 2500 SPM (根據腳踏板的踩踏程度可變) Max. 2500 SPM (Variable according to the paddle operation)
使用針型 Needle Type	UY180GVS SERV7 Nm140
縫紉針距 Stitch Length	2.8mm (根據齒輪可更改為 2.3mm、3.2mm、3.6mm) , 選項: 2.1mm、2.5mm、4.2mm 2.8mm (2.3mm、3.2mm、3.6mm are also available by changing gear) Options: 2.1mm、2.5mm、4.2mm
下擺內裡尺寸 Trousers Bottom Size	280~600mm (下擺寬 140~300mm) 280~600mm (Bottom circumference 140~300mm)
三層卷邊寬度 Hem Width	15~25mm 
縫紉開始 Sewing Start Position	根據接頭檢測器自動決定位置 (可依使用者需求設定) Sensor control by positioning detector (Capable of setting according to user's requirement)
縫紉結束 Sewing End	根據接頭檢測器做動結束後計算針數 (可依使用者需求設定) After triggering sensor, system will keep sewing delay stitch number (Capable of setting according to user's requirement)
氣體消耗量 Air Consumption	4L/min
氣壓 Air Pressure	0.5 Mpa
電源電壓 Voltage	單相 AC200~240V 50/60Hz Single Phase AC200~240V 50/60Hz
機器尺寸 Dimensions	寬830×深670×高1700mm (含桌板、線架) (W)830×(D)670×(H)1700mm (With table and thread stand)
生產效率 Production Capacity	寬度: 220mm、針數: 158、縫距: 2.8mm、車縫速度: 2500 SPM、 車縫時間: 7 sec/褲口、產速: 17 sec/件 Width: 220mm、Total stitch: 158、Stitch length: 2.8mm、Sewing speed: 2500 SPM、 Circle time: 7 sec/trouser leg、Output: 17 sec/piece

ASL-JBH100



-  品質提高
Excellent Quality
-  產量加倍
Multiplied Output
-  成本銳減
Reasonable Cost



高林股份有限公司
KAULIN MFG. CO., LTD.

TOP 100 TAIWAN BRANDS ISO 9001:2000
CE ISO 14001:2004

由於對產品的改良及更新，本產品型錄之產品規格及外觀的修改恕不事先通知！
The specification and/or appearances of the equipment described in this catalogue are subject to change without previous notice because of modification.

ASL-JBH100

Automatic Bottom Hemming Machine

自動轉腳機